

THERMODYNAMIC WATER HEATER

TWH 200 E and TWH 300 E:

Thermodynamic water heater on ambient air or on outside air with electrical resistance.

TWH 300 EH:

Thermodynamic water heater on ambient air or on outside air with heat exchanger for connecting to a boiler or solar, and electrical resistance.



TWH



Domestic hot water



Thermodynamic module
air/water



Electricity
(energy supplied
to the compressor)



Natural renewable energy
free of charges



TWH floor-standing thermodynamic storage water heaters can be connected to the ambient air or the outside air down to -5°C .

They enable domestic hot water to be heated up to 65°C and are therefore perfectly suitable for the replacement of an electric water heater.

The TWH 200 E and 300 E models are fitted with a 2.4 kW safety resistor.

The TWH 300 EH models are also fitted with a 1.6 kW electrical safety resistor and an additional exchanger for hydraulic back-up by boiler or solar system.

They comprise principally:

- Enamelled tank, protection by impressed current anode
- Rotary compressor
- Evaporator made of copper pipes and aluminium vanes
- Aluminium condenser fitted around the tank
- Specific regulator for a DHW application, including programming various operating modes, auxiliary heating management, the anti-legionella function, the antifreeze mode, automatic defrosting (see page 3).
- Very thick insulation (0% CFC)

CONDITIONS OF USE

Max operating temp.: - tank: 90°C
- exchanger (TWH 300 EH): 90°C

Max operating pressure: - tank: 10 bar
- exchanger (TWH 300 EH): 10 bar

Air temperature for heat pump functioning: - 5 to + 35°C

THE VARIOUS MODELS AVAILABLE

Thermodynamic water heater	Model	Capacity l	Heat pump output kW
 <p>With heat pump on ambient air or outside air for DHW heating until 65°C</p>	With electrical safety resistance	TWH 200 E 210	1.7
		TWH 300 E 270	1.7
	With electrical safety resistance and heat exchanger for connecting to a boiler or solar	TWH 300 EH 265	1.7

TECHNICAL SPECIFICATIONS

MAIN DIMENSIONS (MM AND INCHES)

TWH 200 E - TWH 300 E

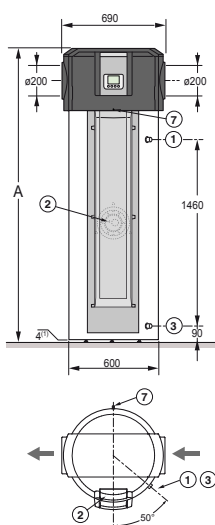

TWH 300 EH

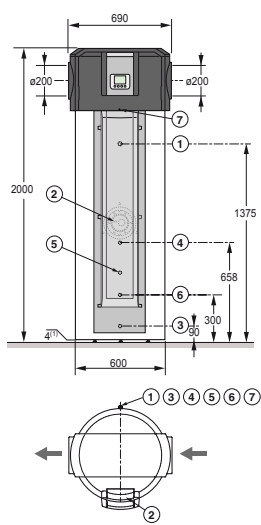

TWH	200 E	300 E
A (mm)	1 690	2 000

- ① DHW outlet (without or with dielectric connector) G 3/4"
- ② Electrical resistance

- ③ DCW inlet (without or with dielectric connector) G 3/4"
- ④ Hydraulic exchanger inlet G 3/4"
- ⑤ Sensor tube for exchanger sensor Ø16mm
- ⑥ Hydraulic exchanger outlet G 3/4"
- ⑦ Condensates evacuation tube PVC Ø16 x 12mm

TECHNICAL SPECIFICATIONS

Max operating temp.:
 - tank: 90°C
 - exchanger (TWH 300 EH): 90°C

Max operating pressure:
 - tank: 10 bar
 - exchanger (TWH 300 EH): 10 bar

Air temperature for heat pump functioning: - 5 to + 35°C

Model	TWH	200 E	300 E	300 EH
Capacity	l	210	270	265
Heat pump output*	W	1700	1700	1700
Absorbed electrical power by the heat pump*	We	500	500	500
COP*		3.5	3.7	3.6
Electrical resistance output	W	2400	2400	1600
Power supply voltage	V	230 V Mono	230 V Mono	230 V Mono
Circuit breaker	A	16	16	16
Exchanger surface of TWH 300 EH	m ²	-	-	1
Heating time 15-51°C	h	5	7	7
Quantity of DHW provided at 40°C (cold water at 15°C)	l	240	357	358
Qpr	kWh/24h	0.73	0.67	0.75
Air flow rate	m ³ /h	385	385	385
Available air pressure	Pa	50	50	50
Maximum length of the ø160 air connection	m	39	39	39
Refrigerant R 134 A	kg	10/20	10/20	10/20
Sound pressure**	dB(A)	1.45	1.45	1.45
Weight empty	kg	92	105	123

* Value for water heating from 15 to 51°C with air inlet temperature of 15°C and 70% HR according EN 255-3
 ** at 2 m from the appliance

COMPONENTS

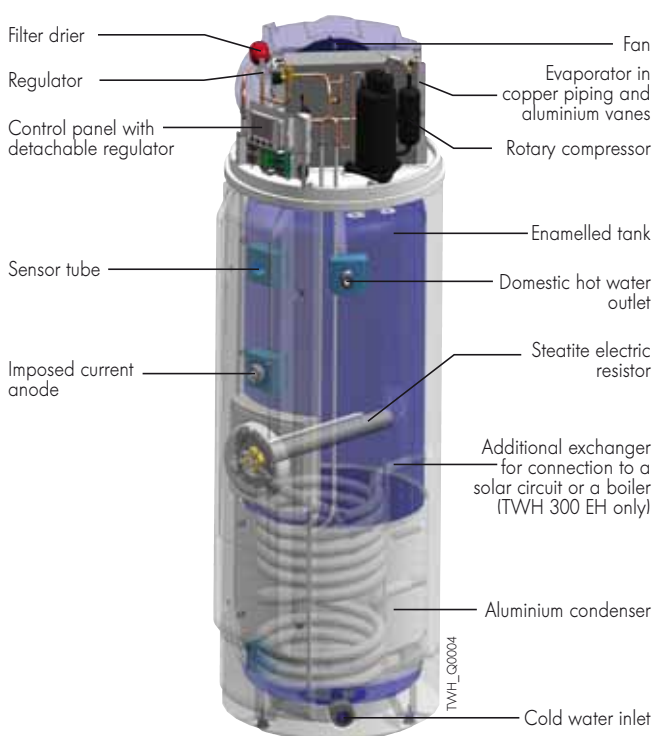

THE CONTROL PANEL

PRESENTATION OF THE CONTROL PANEL

The control panel fitted to TWH thermodynamic water heaters consists of an easy to use, intuitive, programmable control system, which is also detachable to be wall-mounted in the desired place. It is used to select various operating modes (Automatic, Eco, Boost and Holidays). Domestic hot water production can be further optimised thanks to the off peak/peak hours contact or via suitable timer programming: three adjustable DHW comfort periods per day can therefore be

programmed. The control system can also be used to regulate the desired volume of domestic hot water with management of the tank heating mode (visualised on the display unit): by the HP module, the electric resistor, the hydraulic back-up (TWH 300 EH model) or the various modes combined. It also incorporates a time metering function as well as other functions such as antifreeze protection, anti-legionella, automatic defrosting.

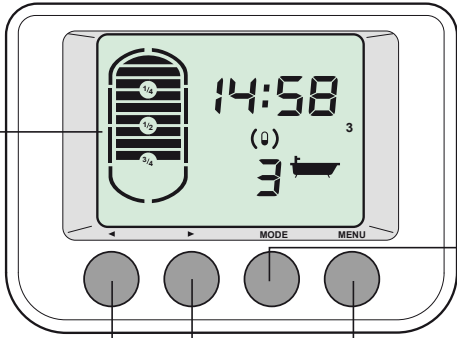

Display
generously sized with simple, intuitive display of the operating modes, timer programming, water quantity or number of baths available, etc.

Navigation keys
and parameter settings with + or -

«Menu» key
- Access to the settings (time/date/programme)
- The meters and other parameters
- And the error history or **Reset key**

Setting the operating mode:

- **Automatic:** «DHW comfort» programme enabled, DHW production is handled by the HP module and the electric back-up, if necessary (plus hydraulic back-up for TWH 300 EH)
- **Eco:** «reduced» programme enabled, DHW production is handled only by the HP module
- **Boost:** forced operation, DHW production is handled simultaneously by the HP module and the electric back-up (and the hydraulic back-up, where applicable) for a period of 3 hours modifiable!
- **Holidays:** no DHW production for a programmable period; the DHW temperature is nonetheless kept at +10°C to guarantee antifreeze protection or **Validation key**

OPTIONAL EQUIPMENT

EH 205
Adapter sleeve Ø 200 on 160mm - Package EH 205
90° elbow Ø 160mm - Package EH 77



TWH_LQ0016
PAC_Q0030

EH 206
Insulated flexible duct Ø 160mm, length 3 m - Package EH 206
Set of fixing clamps Ø 160mm - Package EH 207



TWH_LQ0018
TWH_LQ0017

Passages through walls Ø 160mm - Package EH 208

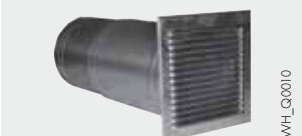

TWH_LQ0010

Outside grate Ø 160mm (aluminium) - Package EH 209



TWH_LQ0011

INFORMATION REQUIRED FOR INSTALLATION

INSTALLING

To ensure sufficient air renewal, the minimum volume of the room must be 30m^3 .

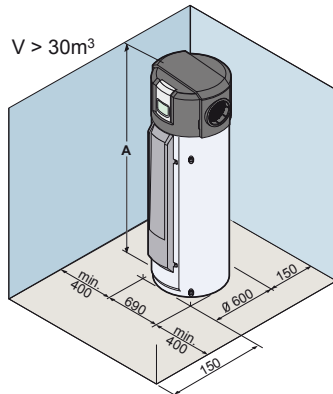

TWH_F0005A

TWH	200 E	300 E	300 EH
A (mm)	1 690	2 000	2 000

Examples of installations:

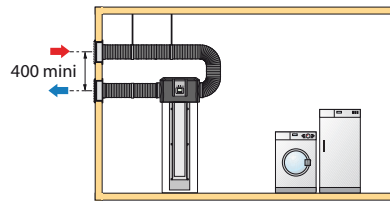

Connection to the outside air

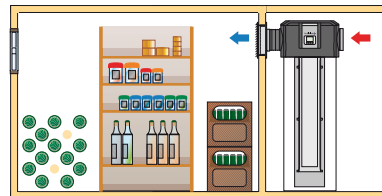

In a cellar (unheated room): can be used to recover calories from the room and keep products cool, for example.

TWH_F0009

ELECTRICAL CONNECTION

TWH thermodynamic water heaters are delivered with one 230 V/50 Hz power cable. The electrical connection must be in compliance with the NFC 15.100 standard. The water heater must be powered by an electrical circuit comprising an omnipolar switch with an opening gap $> 3\text{mm}$, protected by a 16 A circuit breaker.

The TWH is fitted with a «Peak Hours/Off Peak Hours» contact, allowing it to be installed as a replacement for an existing electric water heater without having to modify the installation. Connection of this contact also makes it possible not to enable operation of the HP module and the electric back-up during peak hours (to give priority to heating by hydraulic solar back-up, for example, on the TWH 300 EH models).

HYDRAULIC CONNECTION (TWH 300 EH MODEL)

Coupling with solar collectors (collector surface areas between 3 and 5m^2 are suitable) makes it possible to meet basic DHW needs during the day; additional needs up to 65°C can then be provided by the HP module.

Coupling with a boiler can provide additional comfort if DHW needs are temporarily higher.

TWH 300 EH with hydraulic boiler back-up

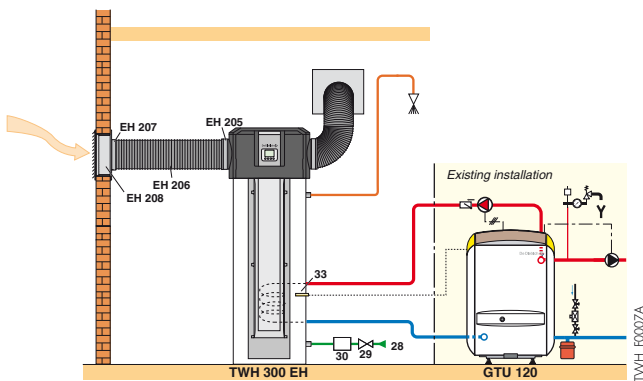

TWH_F0007A

TWH 300 EH with hydraulic solar back-up

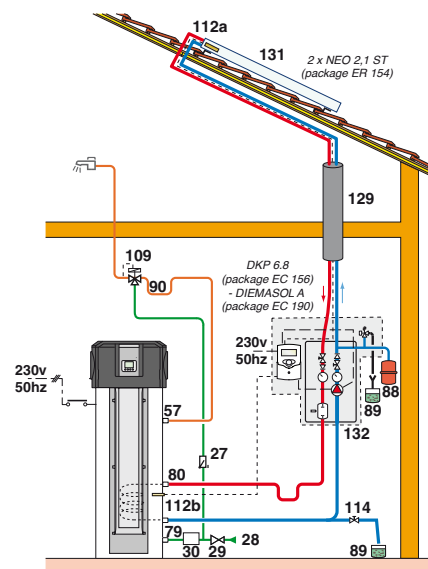

Key

- | | |
|---|--|
| 27 Non-return valve | 89 Container to solar fluid |
| 28 Domestic cold water inlet | 90 Antithermosiphon loop |
| 29 Pressure reducer | 109 Thermostatic mixer tap |
| 30 Sealed safety device calibrated to 7 bar | 112a Solar collector sensor |
| 33 Domestic hot water temperature sensor | 112b Solar DHW tank sensor |
| 57 Domestic hot water outlet | 114 Primary solar circuit filling and draining circuit |
| 79 Primary outlet of heat exchanger | 129 Duo-pipes |
| 80 Primary inlet of heat exchanger | 131 Collector field |
| 88 Solar circuit expansion vessel | 132 Complete solar station with DIEMASOL control unit |

DE DIETRICH THERMIQUE

S.A.S. with corporate capital of 22 487 610 €
 57, rue de la Gare - F - 67580 Mertzwiller
 Tel. +33 3 88 80 27 00 - Fax +33 3 88 80 27 99
www.dedietrich-heating.com

De Dietrich